

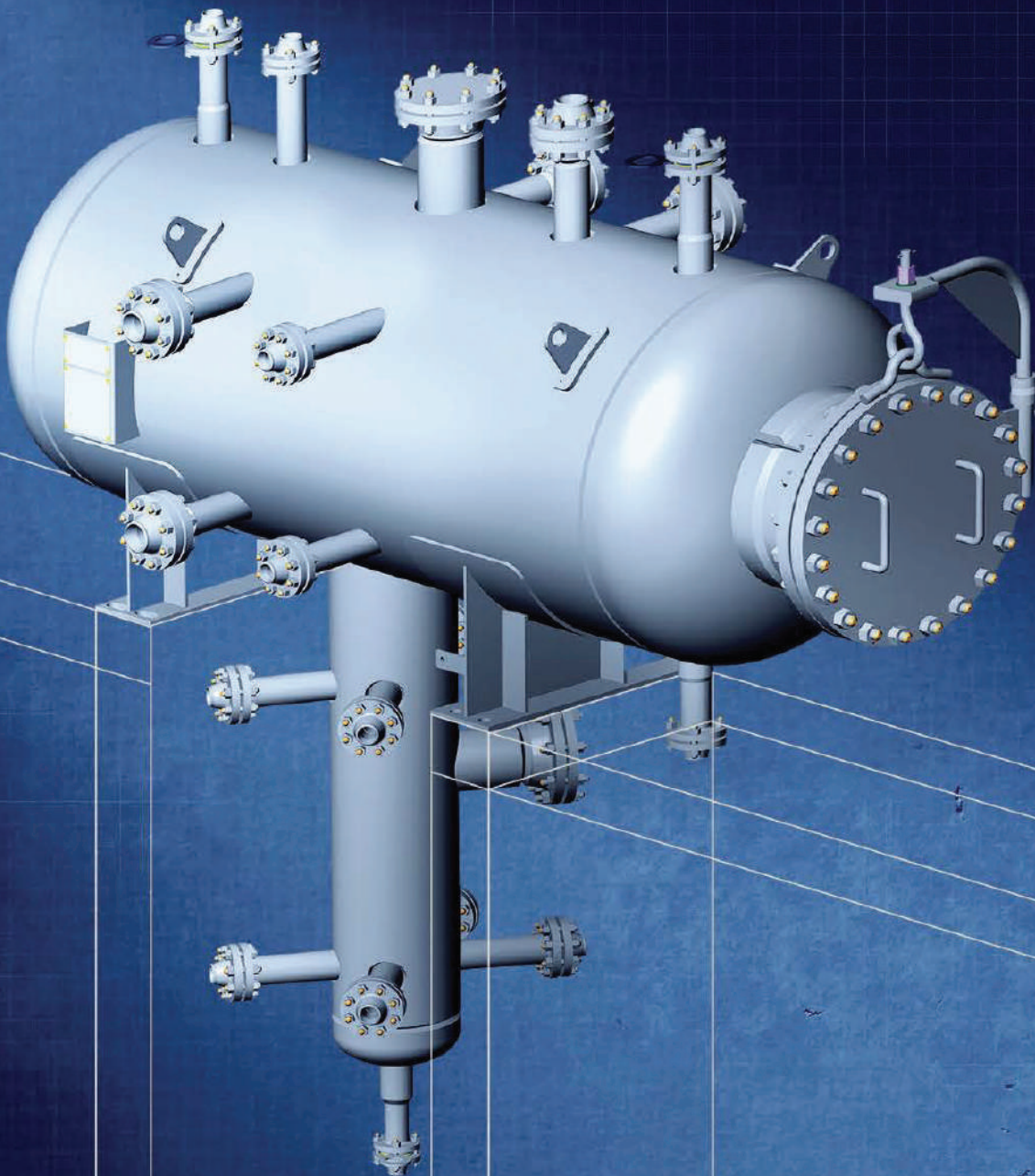

# PROCESS EQUIPMENT

## OIL & GAS









## **PRODUCTION**

EQUIPMENT  
WITH EXCELLENT  
EFFICIENCY

Perfect location in Agean Free Zone Area, our facility ensures consistently high quality, adhering to international codes and standards such as CE, GOST, EAC, ISO, UNI EN, and ASME. We guarantee excellence through rigorous testing methods, including X-ray, magnetic particle, ultrasonic, and liquid penetrant testing. Our custom-tailored solutions are designed to meet each customer's unique needs, with dedicated supervision of installation and commissioning to ensure optimal performance.

# THE MACHINERY PRODUCED

**THE EQUIPMENT PRODUCED IN OUR HUM WORKSHOP IS THE RESULT OF ADVANCED ENGINEERING PRACTICES COMBINED WITH CUTTING-EDGE TECHNOLOGY. EVERY SINGLE PIECE IS METICULOUSLY CRAFTED WITH EXCEPTIONAL WORKMANSHIP, ENSURING IT IS PERFECTLY GRADED AND SUITED FOR ITS SPECIFIC APPLICATION. OUR WORKSHOP PROUDLY HOLDS AN ISO 9001 QMS CERTIFICATION, WHICH GUARANTEES THAT THE HIGHEST QUALITY STANDARDS ARE RIGOROUSLY MAINTAINED.**

**FURTHERMORE, OUR MACHINERY AND EQUIPMENT ARE DEVELOPED USING THE MOST SOPHISTICATED TECHNOLOGIES AVAILABLE GLOBALLY. THEY ARE CAREFULLY DESIGNED AND MANUFACTURED IN STRICT COMPLIANCE WITH EN STANDARDS FOR PRESSURE VESSELS AND MECHANICAL DESIGN PROGRAMS. OUR DESIGN PROCESS LEVERAGES POWERFUL TOOLS SUCH AS INVENTOR-3D DESIGN AND SIMULATION, SOLIDWORKS-3D DESIGN, AND AUTOCAD-2D DESIGN TO ACHIEVE PRECISION AND EXCELLENCE IN EVERY PROJECT.**





# ENGINEERING

QUALIFIED  
ENGINEERING  
SERVICE

Our approach to project planning and execution is comprehensive and detailed, adhering to the latest industry standards and best practices. We utilize modern 3D design and simulation programs to ensure precision and efficiency in every project. Additionally, all our processes are aligned with the ISO 9001 Quality Management System, guaranteeing the highest level of quality and consistency.

# TEAM OF EXPERTS

HUM'S TEAM OF ENGINEERS CONSISTENTLY STRIVES TO EXCEED CLIENT EXPECTATIONS BY DELIVERING INNOVATIVE AND COST-EFFECTIVE ENGINEERING SOLUTIONS THAT ARE CUSTOMIZED TO MEET THE UNIQUE NEEDS OF EACH PROJECT. THE HIGHEST DEGREE OF CARE AND SKILL IS GIVEN IN ACCORDANCE WITH GENERALLY ACCEPTED ENGINEERING PRACTICE AND THE BEST ACKNOWLEDGED TECHNOLOGICAL PRINCIPLES.

THE ENGINEERING SERVICES ARE DESIGNED ON CE STANDARDS WITH 3D PIPING AND ARRANGEMENT DESIGN, AS WELL AS SIMULATION PROGRAMS.

- ◆ AUTOCAD PIANT 3D
- ◆ SOLIDWORKS SIMULATION
- ◆ AUTODESK INVENTOR 3D
- ◆ AUTODESK MECHANICAL
- ◆ NAVISWORKS
- ◆ FINITE ELEMENT ANALYSIS - FEA
- ◆ 3D ANIMATION
- ◆ PASSAT PRESSURE VESSELS ANALYSIS
- ◆ PV ELIT PLUS

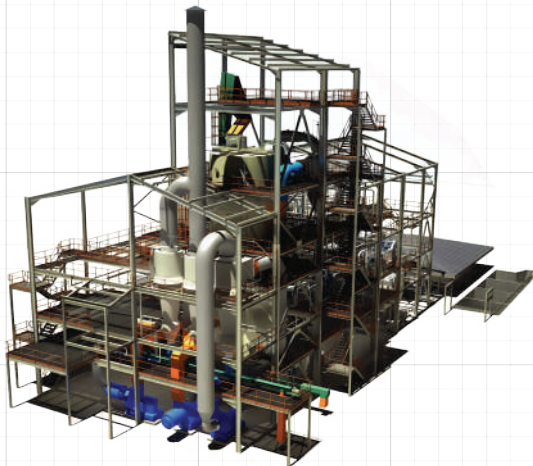

1 PLANT DESIGN

2 PROCESS DESIGN

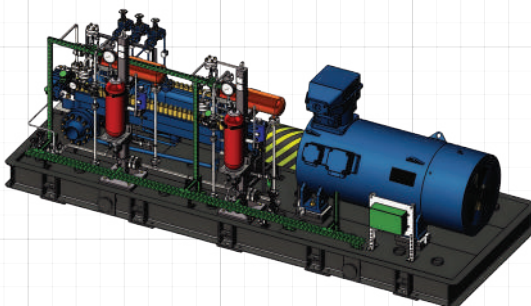

3 EQUIPMENT DESIGN



# PRESSURE VESSELS

Pressure vessels are designed for receiving, storing and dispensing of liquid and gaseous products under overpressure up to 10 MPa (100 kgf/cm<sup>2</sup>) and temperatures from 63K (-21°C) to 973K (+70°C), as well as at atmospheric pressure and under vacuum (with residual pressure not lower than 5 mm Hg).

The pressure of the coolant in the jacket or coil for the above-mentioned types of apparatuses should not exceed 0.6 MPa (6.0 kgf/cm<sup>2</sup>). Discharge of liquid media can be carried out both by gravity and squeezing by compressed air, process and inert gas. Vertical apparatuses without jackets and coils can be used as settling tanks.

# STEEL VESSELS

## FOR CHEMICAL MEDIUM

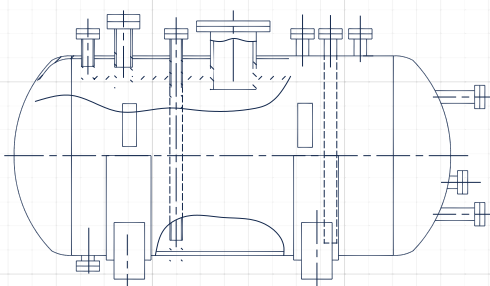
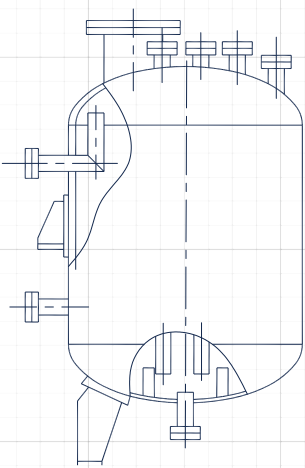
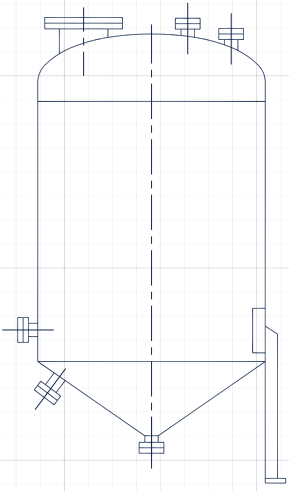
TYPE OF VESSEL	GENERAL PARAMETERS		SKETCH
	Rated volume, m <sup>3</sup>	Rated pressure, MPa	
<b>HORIZONTAL WITH ELLIPTICAL BOTTOMS</b> ГЭЭ*	6,3; 10; 16; 25; 40; 50; 63; 80; 100	0,6; 1,0; 1,6	
<b>VERTICAL WITH ELLIPTICAL BOTTOMS</b> БЭЭ*	1; 2; 3,2; 5; 6,3; 10; 16; 25; 32; 40; 50; 63	0,3; 0,6; 1,0; 1,6	
<b>VERTICAL WITH CONICAL BOTTOM AND ELLIPTICAL TOP COVER</b> (БКЭ)*	1; 2; 3,2; 5; 6,3; 10	0,6; 1,0	

# STEEL VESSELS

## FOR AIR AND HYDROCARBON MEDIUM

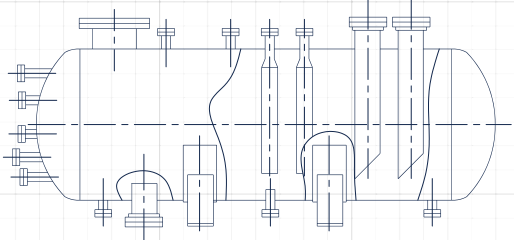
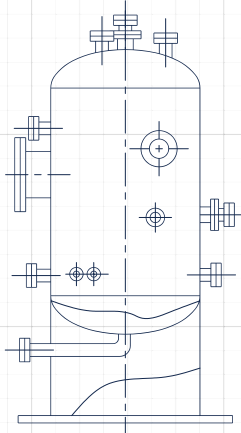
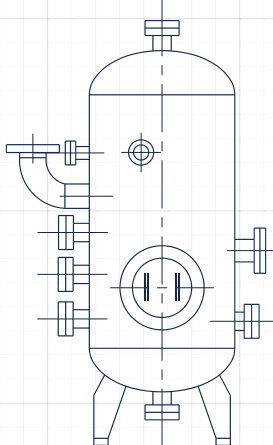
TYPE OF VESSEL	GENERAL PARAMETERS		SKETCH
	Rated volume, m <sup>3</sup>	Rated pressure, MPa	
<b>HORIZONTAL CYLINDRICAL</b> (ГЛ)*	4; 8; 10; 16; 20; 25; 32; 50; 80; 100; 200	1,0; 1,6; 2,5	
<b>VERTICAL CYLINDRICAL FOR LIQUID MEDIUM</b> (БЦЖ)*	2; 4; 6,3; 10; 16; 25; 32; 50; 80; 100	0,3; 0,6; 1,0; 1,6	
<b>VERTICAL CYLINDRICAL FOR GAS MEDIUM AND AIR</b> (БЦГ)*	0,5; 1; 1,6; 2; 3,2; 4; 6,3; 8; 10; 16; 20; 25	1,0; 1,6; 2,5	

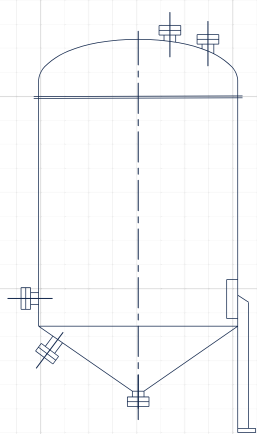
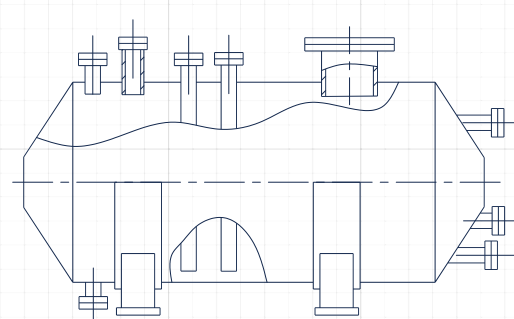
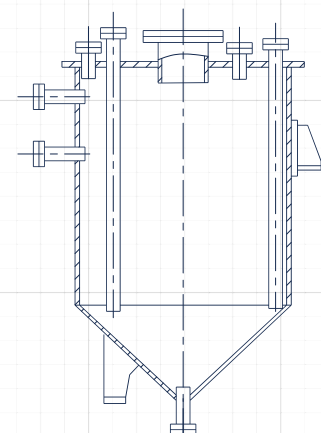
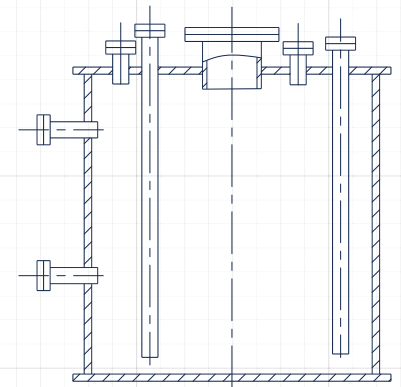
<p><b>VERTICAL WITH CONICAL BOTTOM AND ELLIPTICAL TOP COVER</b> (БКЭ)*</p>	<p>1; 2; 3,2</p>	<p>0,6</p>	
<p><b>HORIZONTAL CYLINDRICAL WITH CONICAL BOTTOM</b> (ГКК)</p>	<p>10; 16; 25; 40; 50; 63; 80; 100</p>	<p>0 (atmospheric)</p>	
<p><b>VERTICAL WITH CONICAL BOTTOM AND FLAT TOP COVER</b> (БКП)*</p>	<p>10; 16; 25</p>	<p>0 (atmospheric)</p>	
<p><b>VERTICAL WITH FLAT BOTTOM AND FLAT TOP OR WITH CONICAL TOP AND FLAT BOTTOM</b> (ВПП, ВПК)*</p>	<p>10; 16; 25; 32; 40; 50; 63</p>	<p>0 (atmospheric)</p>	

\*if it is necessary to maintain the set temperature in the vessels, the vessels can be equipped with external or internal heat-exchanging devices, as required in the Data Sheet. To order all types of vessels it is necessary to fill in the Data Sheet.



# SHELL AND TUBE HEAT EXCHANGERS

Fixed tubesheet shell-and-tube heat exchangers with increased thermal effectiveness c with expansion pipe on shell in diameter 159, 273, 325, 400, 600, 800, 1000, 1200, 1400, 1600, 1800 mm are intended for heating and cooling of liquids and fluids in technological processes of oil refining, chemical, petrochemical and natural gas industries.

Heat exchangers are subdivided: for its intended purpose into heat exchangers (T), refrigerators (X), condensers (K), evaporators (И); in design into fixed tubesheet heat exchangers (H) and heat exchangers with expansion pipe on shell (K). In vessels the smooth tubes (Г) are used, as well as the tubes with moving ring grooves — diaphragmatic tubes (Д).

Design standards: ISO, API, OCT, TEMA, ASME

- ✦ Horizontal and vertical type with float head
- ✦ With straight pipes and U-type pipes
- ✦ With fixed tube sheet

# SHELL AND TUBE HEAT EXCHANGERS

## TECHNICAL CHARACTERISTICS

NOMINAL PRESSURE, MPA (KGF / CM <sup>2</sup> )	0,6 (6); 1,0 (10); 1,6 (16); 2,5(25); 4,0 (40)
HEAT-TRANSFER SURFACE, M <sup>2</sup>	1 - 1536
THE DIAMETER AND WALL THICKNESS OF THE HEAT EXCHANGE TUBES, MM THE DIAMETER AND WALL THICKNESS OF THE HEAT EXCHANGE TUBES, MM	20x2; 25x2
TUBE LENGTH, M	1, 2, 3, 4, 6, 9
NUMBER OF STROKES ALONG THE TUBES	1, 2, 4, 6
TEMPERATURE OF HEAT EXCHANGE MEDIUM, °C	from -70 to +350
MATERIAL OF CONSTRUCTION	carbon steel, stainless steel, brass

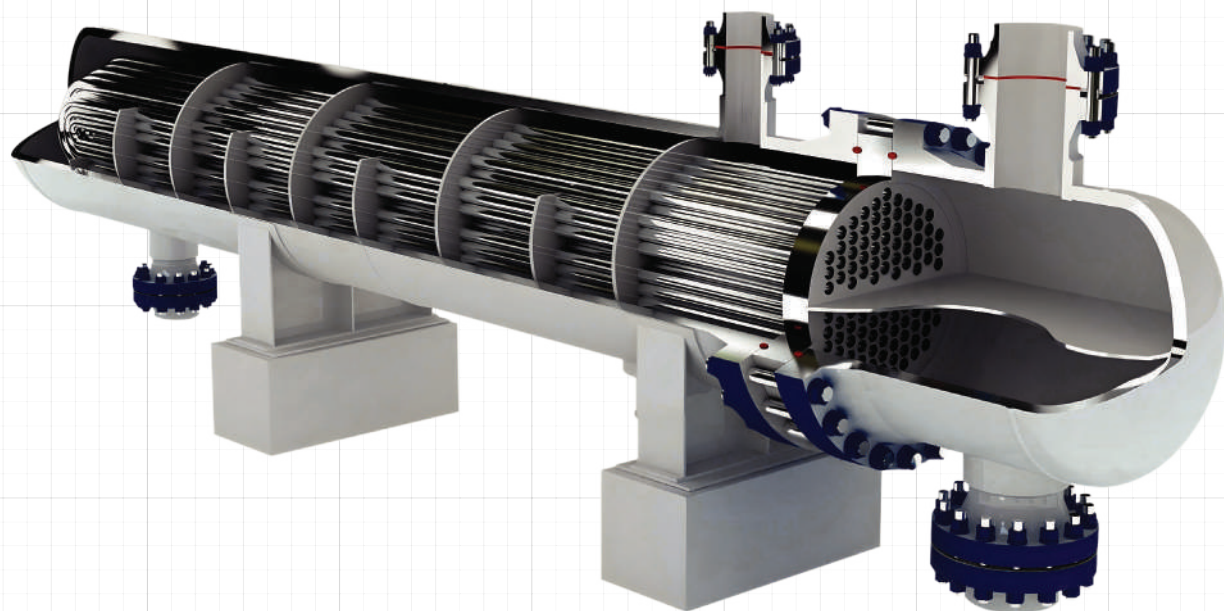



# FINNED TUBE AIR COOLED HEAT EXCHANGERS

Finned tube air heat exchangers are intended for cooling gases and liquids, condensing steam and vapor-liquid media in technological processes of the chemical, petrochemical, oil refining, oil and gas industries with a medium pressure from 0.6 to 6.3 MPa, or under vacuum with residual pressure not lower than 665 Pa and temperature not higher than 300 ° C.

In our production range exist following type and models:

- ✦ Horizontal: AVG, 1AVG (ABГ, 1ABГ)
- ✦ Zigzag type: 1AVZ, AVZ, AVZ-D (1AB3, AB3, AB3-Д)
- ✦ Small flowtype: ACM-G, AVIM-V (ABM-G, ABM-B)

Depending on the model of the device, the geometric dimensions can vary in width from 1.38 m to 6 m, and in length from 1.5 m to 15 m. The materials used for the production of these models comply with the standards for pressure vessels according to ISO 16528-1:2007/ GOST 34347- 2017, as well as EN 13445-2 and ASME Section II.

Depending of Customer order in scope of supply may be included foundation frame/support, set of blinds (hand operated or pneumatically operated), air humidifier, air heater, pneumatic controller of fan blades.

# AIR COOLED HEAT EXCHANGERS

## TECHNICAL CHARACTERISTICS UNITS AB3-Д

<b>NUMBER OF BAYS, PCS.</b>	6
<b>FINNED SURFACE FACTOR OF TUBES</b>	9; 14,6; 20
<b>HEAT EXCHANGE SURFACE AREA, M<sup>2</sup></b>	3528-12672
<b>NOMINAL PRESSURE, MPA</b>	0,6; 1,6; 2,5; 4,0; 6,3
<b>NUMBER OF BANKS OF TUBES IN THE BAY</b>	4; 6; 8
<b>NUMBER OF STROKES THROUGH THE TUBES IN THE BAY</b>	1; 2; 2a; 4; 4a; 8
<b>LENGTH OF TUBES, M</b>	8
<b>WHEEL DIAMETER OF FAN, MM</b>	2800
<b>ELECTRIC MOTOR NOMINAL RATING, KW</b>	22; 30
<b>THE NUMBER OF FANS IN THE UNIT</b>	2
<b>UNIT WEIGHT, KG (DEPENDING ON SIZE)</b>	21260 - 43300

## SKETCH

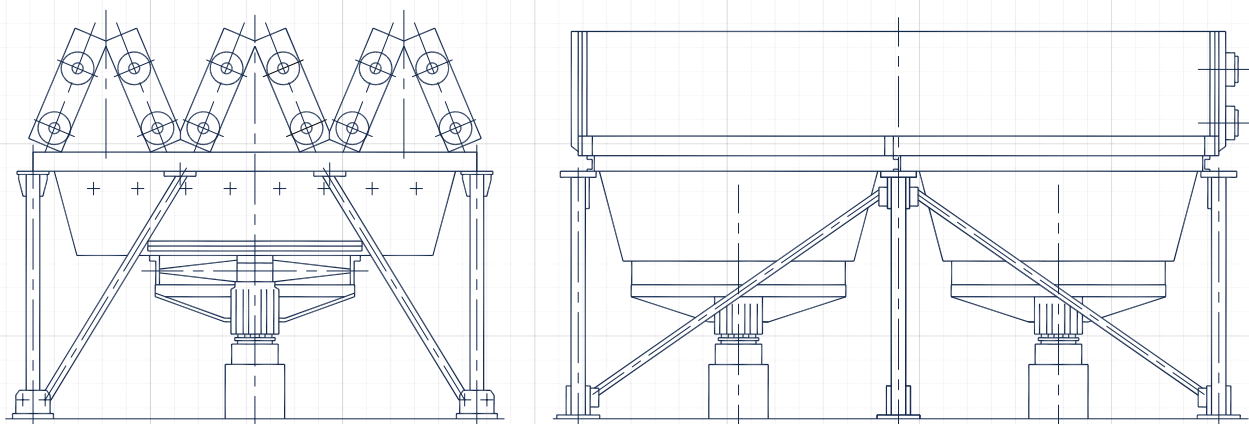

# AIR COOLED HEAT EXCHANGERS

TECHNICAL CHARACTERISTICS	UNITS 1ABF	UNITS ABM	UNITS AB33, 1AB3
NUMBER OF BAYS, PCS	2	1	6
FINNED SURFACE FACTOR OF TUBES	9; 20	9; 14.6; 20	9; 20
HEAT EXCHANGE SURFACE AREA, M <sup>2</sup>	848-4766	105-815	2298-6396
NOMINAL PRESSURE, MPA	0,6; 1,6; 2,5; 4,0; 6,3	0,6; 1,6; 2,5; 4,0; 6,3	0,6; 1,6; 2,5; 4,0; 6,3
TUBE BANKS COUNT PER BAY	4; 6	-	-
NUMBER OF BANKS OF TUBES IN THE BAY	IN A 4-ROW BAYS 1; 2; 4 IN A 6-ROW BAYS 1; 2; 3; 6	4; 6; 8	4; 6
NUMBER OF STROKES THROUGH THE TUBES	-	1; 2; 3; 4; 6; 8	-
NUMBER OF STROKES THROUGH THE TUBES IN THE BAY	-	-	1; 2; 2a; 4; 4a; 8
LENGTH OF TUBES, M	4; 8	1,5; 3	6
WHEEL DIAMETER OF FAN, MM	2800	800	5000
ELECTRIC MOTOR NOMINAL RATING, KW	22; 30	3	37; 55; 75
THE NUMBER OF FANS IN THE UNIT	1; 2	1; 2	1
UNIT WEIGHT, KG (DEPENDING ON SIZE)	6640-20120	1176-3510	16900-27000

## SKETCH UNITS 1ABF

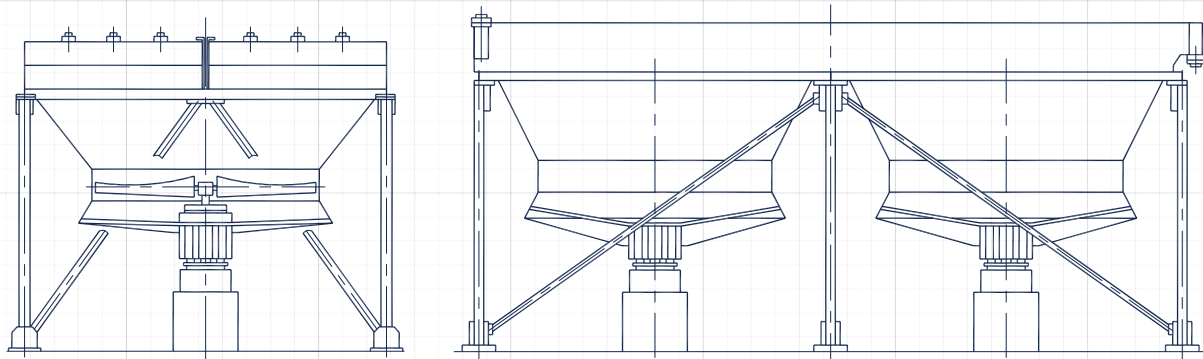

**SKETCH UNITS ABM**

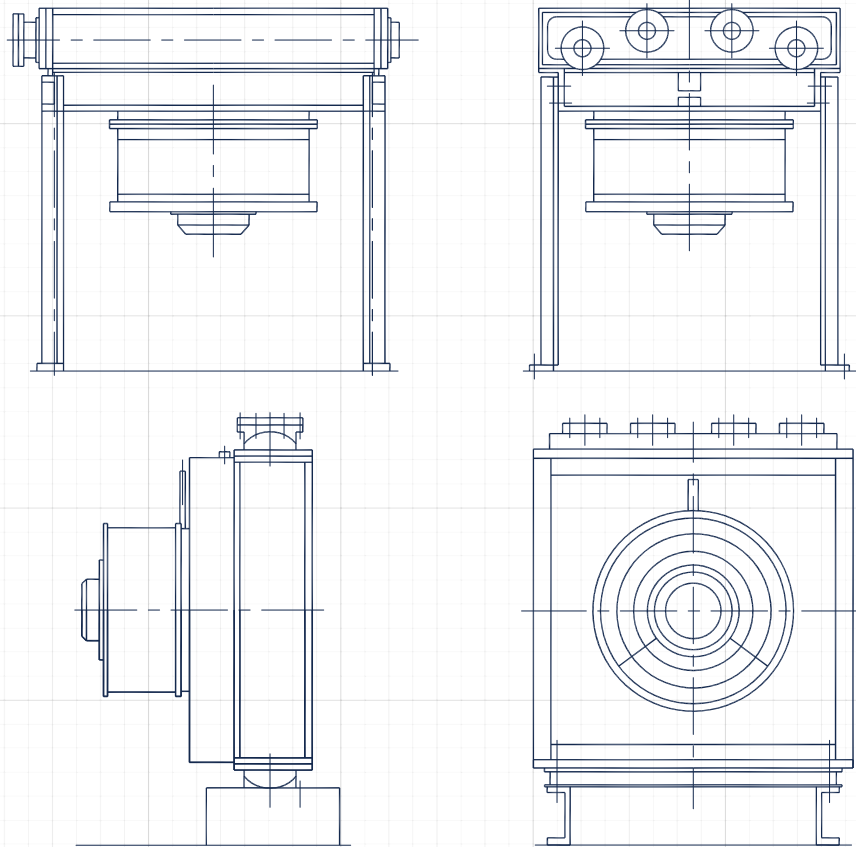

**SKETCH UNITS AB33, 1AB3**

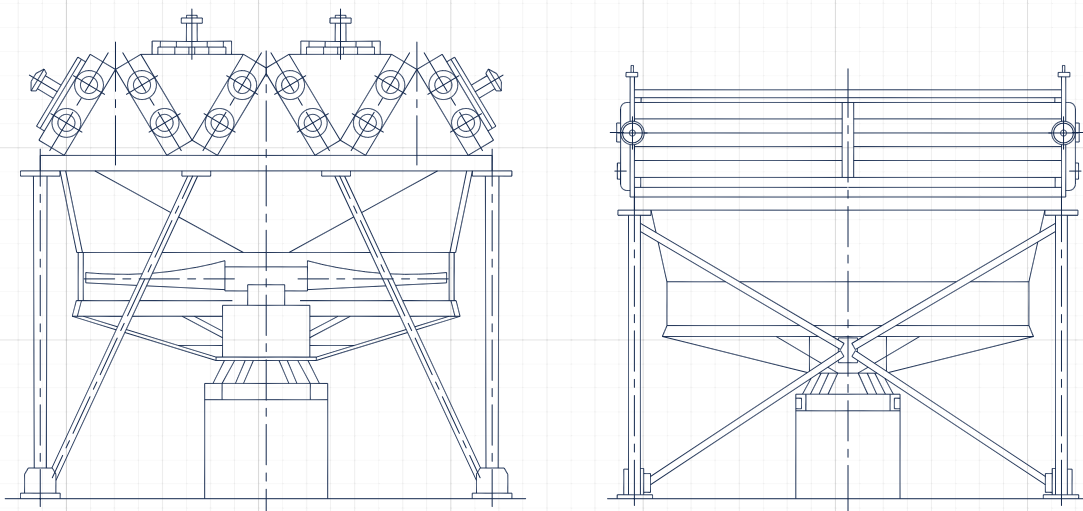

# PLATE TYPE HEAT EXCHANGERS

Plate-type heat exchangers are characterized by their long period of operation and easy execution of routine maintenance.

The service life of the first unit being out of service – joint packing – is up to 10 years. Operating term of fins is 20-25 years. The cost of replacement seals is in the range of 15-25% of the cost of plate-type heat exchanger, that is more economically of the similar process of replacing the brass tube block in shell-and-tube exchanger, that is 80-90% of the cost of unit.

Development, design and manufacture of plates is certified by the Board of Technical Management (TÜV CERT/Germany) in accordance with DIN ISO 9001/EN 29001.

# THE MAIN COMPONENTS

PLATE PACK 1, CONSISTING OF A NUMBER OF PLATES IN ACCORDANCE WITH THE REQUIREMENTS FOR HEAT TRANSFER SURFACE.

SEALS ON THE PLATES, WHICH PROVIDE RELIABLE INSULATION OF CHANNELS FROM EACH OTHER, AND THE LACK OF FLOWS AND LEAKS. SEALS ALSO DETERMINE THE DIRECTION OF FLOW INSIDE THE HEAT EXCHANGER.

FRAME 6, WHICH COVERS THE PLATE PACK VIA STATIONARY PLATE 2 AND PRESSURE PLATE 3, WHICH IS SUSTAINED BY MEANS OF TIGHTENING BOLTS 5.

CONNECTOR 4 FOR THE INLET AND DISCHARGE OF COOLANTS ARE USUALLY LOCATED ON THE FIXED PLATE HEAT EXCHANGER. IN CASE OF MULTIPASS FLOW, THE NIPPLES ARE LOCATED ON STATIONARY AND PRESSURE PLATES.

THANKS TO PRECISE MANUFACTURING AND RATIONAL DESIGN, GASKETED HEAT EXCHANGERS CAN BE EASILY DISASSEMBLED FOR INSPECTION, MECHANICAL CLEANING OF SURFACE OR OR REPLACEMENT OF PLATES AND SEALS. THE UNIT CAN BE EASILY ASSEMBLED INTO A SINGLE BLOCK. THIS PROCESS CAN BE REPEATED AS MANY TIMES AS IT IS PROVIDED BY THE CONSTRUCTION OF APPARATUS.

WE OFFER THREE STANDARD TYPES OF FRAMES WITH LATERAL COMPRESSIVE BOLTS THAT CAN BE EASILY INSTALLED.

- ✦ FRAMES FOR EXTRA LONG PLATE PACKS
- ✦ FRAMES FOR SHORT PACKETS WITH THE LENGTH OF 250 MM
- ✦ FRAMES WITH SMALL TYPES OF PLATES AND THE AVERAGE LENGTH OF PACKET
- ✦ THE MODULAR TYPE OF CONSTRUCTION ALSO ALLOWS YOU TO CONSISTENTLY ADAPT TO NEW OPERATING CONDITIONS

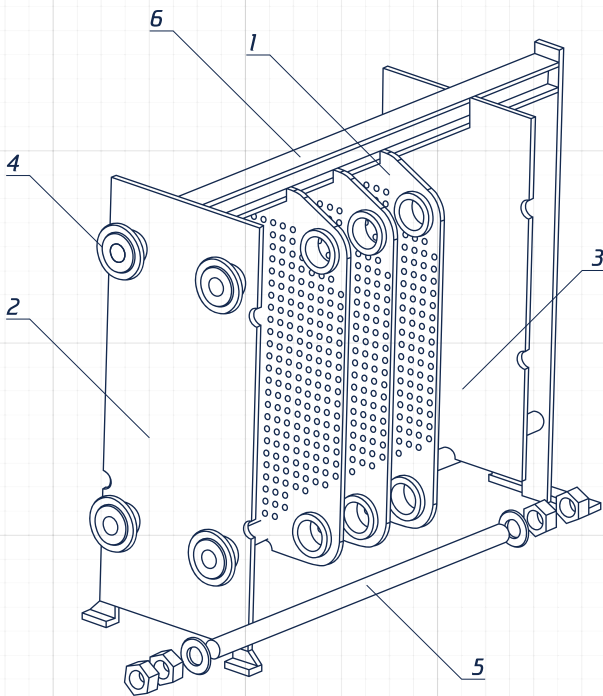



# GAS SEPARATORS

Gas separators are intended for cleaning of natural and associated gas from condensed liquid and mechanical impurities. Input gas separators with an operating pressure of more than 6.3 MPa are intended for previous gas cleaning; final cleaning is carried out in gas separators of second category under the pressure up to 8,8 MPa.

Gas-oil separators of horizontal-shell-type are intended for degassing of oil and associated gas cleaning.

The separators are made of carbon and alloy steels. Separators can be installed in all climatic zones.

Our company design and manufacture complete 2-phase and 3-phase separation units.

# GAS SEPARATORS

## FUNCTION AND APPLICATION:

- ✦ OIL AND GAS SEPARATORS ARE USED FOR OIL DEGASSING AND ASSOCIATED GAS PURIFICATION
- ✦ GAS SEPARATORS DESIGNED TO PURIFY GASES FROM DROPLETS OF LIQUID AND MECHANICAL IMPURITIES
- ✦ LIQUID SEPARATOR IS DESIGNED FOR GRAVITATIONAL SEPARATION OF INSOLUBLE LIQUIDS AND HYDROCARBON GAS IN PROCESS PLANTS

### GAS SEPARATORS CLASSIFIED BY FOLLOWING PARAMETERS:

By installation	By stage of cleaning:	By operation method:	By working pressure:
VERTICAL TYPE HORIZONTAL TYPE HYDROCYCLON TYPE	2-PHASE 3-PHASE	CENTRIFUGAL TYPE INERTIAL TYPE GRAVITATIONAL TYPE	BELOW 0,6 MPA 0,6-2,5 MPA OVER 2,5 MPA

### GENERAL SKETCH WITH INTERNAL DESIGN

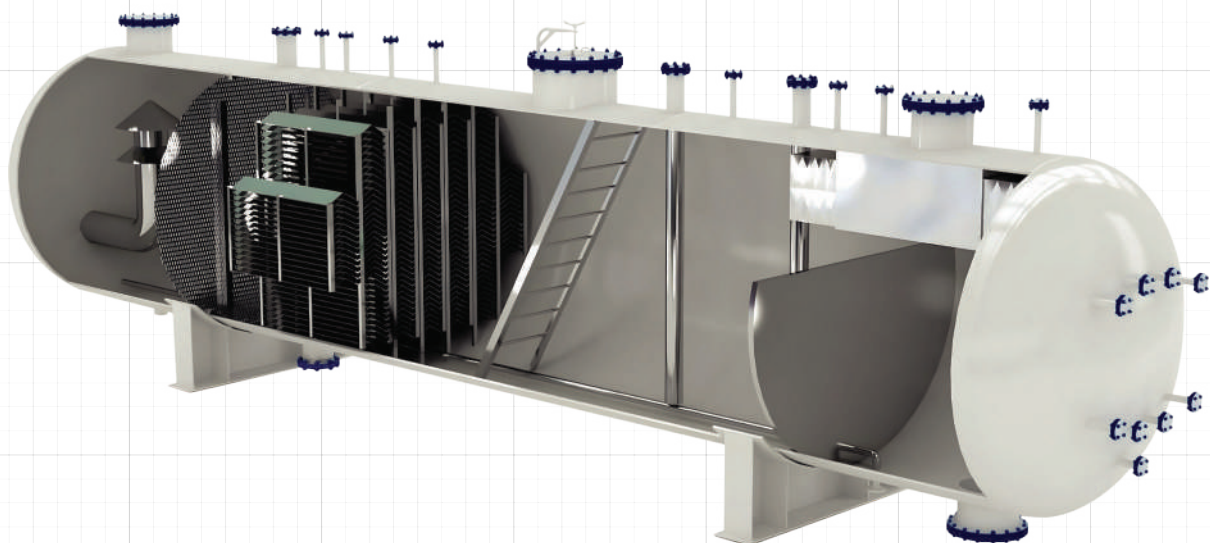



# PROCESS COLUMNS AND MASS EXCHANGE APPARATUS

Equipment designed for mass transfer processes (absorption, desorption, rectification, distillation, etc.), evaporation equipment is used for concentrating solutions in technological installations of oil and gas refining, chemical, petrochemical plants, with a medium pressure  $P_u$  of up to 16.0 MPa and a temperature not higher than 350 °C

Depending on the type of device, the geometric dimensions can be up to 4500 mm in diameter. The materials used for the production of these types comply with the standards for pressure vessels according to ISO 16528-1:2007/GOST 34347-2017 as well as EN 13445-2 and ASME Section II

# STEEL VESSELS

## FUNCTION AND APPLICATION:

MASS EXCHANGE APPARATUS AND COLUMNS ARE DESIGNED TO CARRY OUT PROCESSES IN WHICH THE DISTRIBUTED COMPONENT (ONE OR MORE) IS TRANSFERRED FROM ONE PHASE TO ANOTHER.

MASS EXCHANGE EQUIPMENT CLASSIFY BY APPLICATION AS FOLLOW:

- ✦ DISTILLATION APPARATUS
- ✦ DISTILLATION COLUMNS
- ✦ DISSOLUTION APPARATUS
- ✦ ION EXCHANGE APPARATUS
- ✦ MEMBRANE APPARATUS ABSORBERS
- ✦ ABSORBERS
- ✦ ADSORBERS
- ✦ EXTRACTORS
- ✦ CRYSTALLIZERS
- ✦ DRYERS

BY FUNCTION MASS EXCHANGE APPARATUS DIVIDED BY:

- ✦ WITH CONTINUOUS PHASES CONTACT (FILM & NOZZLE TYPE)
- ✦ WITH STEPPED PHASE CONTACT (DISC SHAPED TYPE)

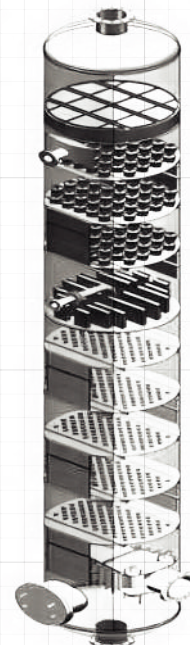

## **HUM**

### **HEAD OFFICE**

Atasehir Blv. Gardenya Plaza 5. Kat. 19

34758 Ataşehir - İstanbul - Türkiye

Tel: +90 216 580 83 13

Fax: +90 216 456 37 06

### **WORKSHOP**

Ege Serbest Bölgesi, Mümtaz Sok. No:20

35410 Gaziemir - İzmir - Türkiye

Tel: +90 232 252 29 22

Fax: +90 232 252 29 23

info@hum.com.tr

**www.hum.com.tr**

03 / 2025

